

JET

JWL-1440VS

WOOD LATHE

**JWL-1440VSM...719400M...
1~ 230V, 50Hz**

PARTS LIST

JPW (Tool) AG

Tämplerlistrasse 5

CH-8117 Fällanden

Switzerland

Phone +41 44 806 47 48

Fax +41 44 806 47 58

www.jettools.com



JWL-1440VS Headstock Assembly – Exploded View

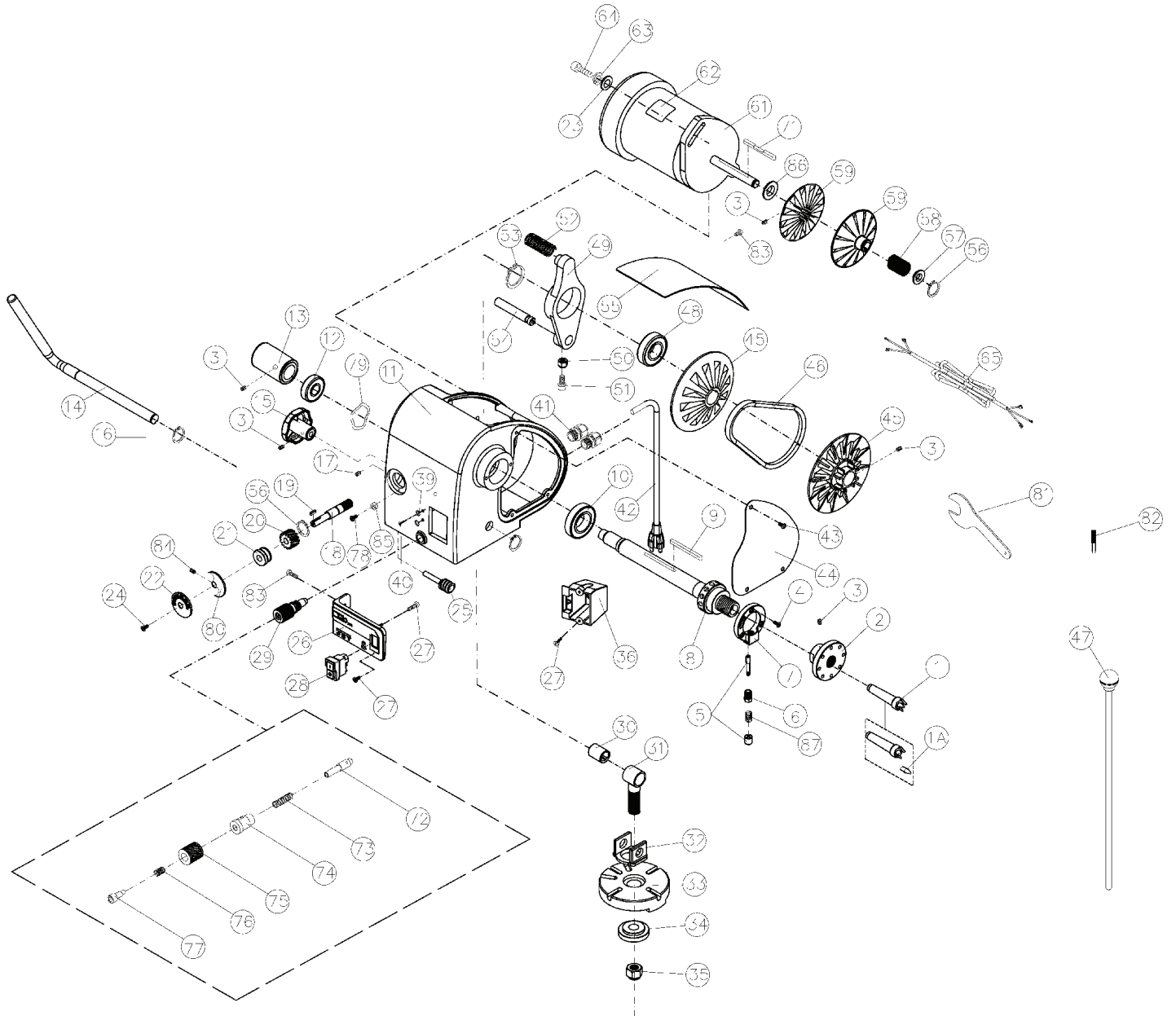

16.1.2 JWL-1440VS Headstock Assembly – Parts List

Index No.	Part No.	Description	Size	Qty
1	JWL 1642-102	Spur Center	MT2	1
1A	JML-3A	Center Point for Spur Center		1
2	6294736E	Faceplate	3"	1
3	6295796	Nylon Insert Socket Set Screw	1/4-20 x 3/8"	8
4	JWL 1440-104	Socket Head Button Screw	#10-24 x 3/4"	3
5	JWL 1440-105	Spindle Lock Pin		1
6	JWL 1440-106	Stud		1
7	JWL 1440-107	Cover		1
8	JWL 1440-108E	Spindle	M33X3.5mm	1
9	JWL 1442-104	Key	4x4x80 mm	1
10	BB-6205ZZ	Ball Bearing	6205ZZ	1
11	JWL 1440-111E	Headstock		1
12	BB-6304VV	Ball Bearing	6304VV	1
13	JWL 1440-113	Handwheel		1
14	JWL 1440-114	Eccentric Rod		1
15	JWL 1440-115	Knob		1
16	JWL 1442-124	C-ring	S19	2
17	TS-0267091	Set Screw	1/4"-20 x 1"	1
18	JWL 1440-118	Worm		1
19	JWL 1440-119	Key	4x4x10 mm	1
20	JWL 1440-120	Gear		1
21	JWL 1440-121	Bushing		1
22	JWL 1440-122E	Speed Chart (includes Disc Plate)		1
23	TS-0680031	Flat Washer	5/16"	2
24	JWL 1440-124	Socket Flat Head Screw	1/4"-20 x 3/8"	2
25	4224B-521	Worm		1
26	JWL 1440-126	Control Panel		1
27	TS-081C052	Pan Head Screw	#10-24 x 3/4"	4
28	JML-65E	Switch		1
29	JWL 1440-129	Pivot Pin Assembly (includes #72 thru 77)		1
30	JWL 1442-127	Bushing		1
31	JWL 1442-128A	Bolt		1
32	JWL 1442-129	Support Bracket		1
33	JWL 1440-133	Index Bracket		1
34	JWL 1442-154	Clamp		1
35	TS-0650081	Nylon Nut	3/4"-10	1
36	JWL 1440-136	Switch Box		1
39	JWL 1442-170	External Tooth Lock Washer	#10	2
40	TS-081C022	Pan Head Screw	#10-24x3/8"	2
41	JWL 1440-141	Strain Relief		2
42	JWL 1440-142E	Power Cord		1
43	TS-2246102	Socket Head Button Screw	M6 x 10	3
44	JWL 1440-144	Motor Cover		1
45	JWL 1442-161	Spindle Pulley Assembly		1
46	JWL 1440-146	V-Belt	RPF 2240	1
47	JWL 1442-164	Knock Out Rod		1
48	BB-6006ZZ	Ball Bearing	6006ZZ	1
49	JWL 1442-145	Shift Lever Bracket		1
50	TS-0561011	Nut	1/4"-20	1
51	TS-0207061	Socket Head Cap Screw	1/4"-20 x 1"	1
52	JWL 1442-142	Spring		1
53	JWL 1442-144	C-ring	S30	1
54	JWL 1236-20	Rack		1
55	JWL 1440-155	Cover		1
56	JWL 1442-139	C-Ring	S16	2
57	JWL 1440-157	Sleeve		1
58	JWL 1440-158	Spring		1
59	JWL 1440-159	Motor Pulley Assembly		1

Index No.	Part No.	Description	Size	Qty
61	JWL1440-161E	Motor (includes #62)		1
	JWL1440-MF	Motor Fan (not shown)		1
	JWL1440-MFC	Motor Fan Cover (not shown)		1
	JWL1440-CSE	Centrifugal Switch (not shown)		1
	JWL1440-CC	Capacitor Cover (not shown)		2
	JWL1440-SC	Starting Capacitor (not shown)	200MFD, 125VAC	1
	JWL1440-RCE	Running Capacitor (not shown)	35 μ f, 250VAC	1
	JWL1440-DC	Dust Cover (not shown)		1
62	JWL1440-162E	Motor Label		1
63	TS-0720081	Lock Washer	5/16"	2
64	TS-0208071	Socket Head Cap Screw	5/16"-18 x 1-1/4"	2
65	JWL1440-165E	Motor Cord		1
71	JWL1440-171	Key		1
72	JWL1440-172	Pivot Index Pin		1
73	JWL1442-175	Spring		1
74	JWL1442-176	Index Bushing		1
75	JWL1442-173	Index Knob		1
76	JWL1442-172	Spring		1
77	JWL1440-177	Socket Head Cap Screw		1
78	TS-0206031	Socket Head Cap Screw	#10-24 x 5/8"	1
79	JWL1442-108	Wave Washer		1
80	JWL1440-180	Speed Limiter		1
81	JWL1221VS-269E	Wrench (includes Rubber Sleeve)		1
82	3520B-271	Spindle Index Pin		1
83	TS-0253031	Socket Head Button Screw	#10-24 x 1/2"	3
84	TS-0267021	Set Screw	1/4"-20 x 1/4"	2
85	TS-0560071	Hex Nut	#10-24	1
86	TS-155010	Flat Washer	M16	1
87	JWL1221VS-132	Spring		1

16.2.1 JWL-1440VS Bed Assembly – Exploded View

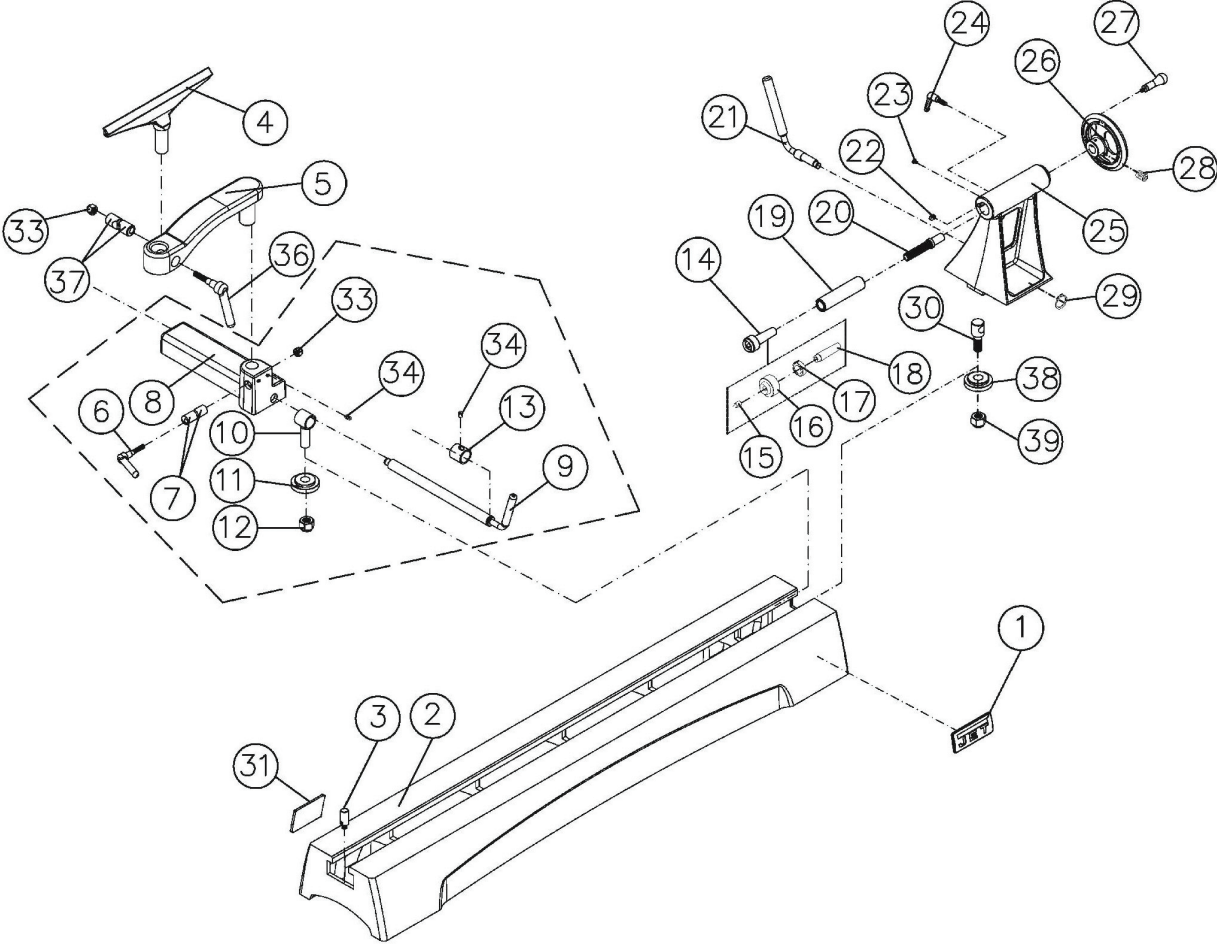

16.2.2 JWL-1440VS Bed Assembly – Parts List

Index No.	Part No.	Description	Size	Qty
1	JET-113	JET Nameplate		1
2	JWL1440-202	Bed		1
3	JWL1440-203	Stud		2
4	JWL1442-205	Tool Rest	12"	1
5	JWL1440-205	Tool Rest Extension		1
	JWL1440-TBA	Tool Rest Base Assembly (includes #6 thru 13, 33, 34)		1
6	JWL1440-206	Handle		1
7	JWL1440-207	Tool Rest Lock Bushing Set		1
8	JWL1440-208	Tool Rest Base		1
9	JWL1442-210A	Tool Support Rod		1
10	JWL1442-128	Clamp Bolt		1
11	JWL1442-154	Clamp		1
12	TS-0650081	Nylon Nut	3/4"-10	1
13	JWL1440-213	Bushing		1
14	708331	Live Center Assembly (includes #15 thru 18)		1
15	JML-52A	Center Point for Live Center		1
16	JML-52	Live Center Head		1
17	BB-6002ZZ	Ball Bearing	6002ZZ	1
18	JML-54	Live Center Shaft		1
	JWL1440-TA	Tailstock Assembly (includes #19 thru 30, 38, 39)		1
19	JWL1440-219	Quill	MT-2	1
20	JWL1440-220	Lead Screw		1
21	JWL1440-221	Tailstock Rod		1
22	JWL1221VS-227	Key		1
23	TS-0253032	Socket Head Button Screw	#10-32x1/2"	1
24	JML-59A	Tailstock Lock Handle		1
25	JWL1440-225	Tailstock Casting		1
26	JWL1440-226	Handwheel		1
27	JWL1442-211	Handle		1
28	TS-0267041	Set Screw	1/4"-20x 3/8"	2
29	JWL1440-229	C-Ring	S-12	1
30	JWL1440-230	Bolt		1
31	JWL1440-231E	ID Label		1
33	TS-0570031	Hex Nut	3/8"	2
34	TS-0267021	Set Screw	1/4"-20x1/4"	4
36	JWL1440-206	Handle		1
37	JWL1440-207	Tool Rest Lock Bushing Set		1
38	JWL1442-154	Clamp		1
39	TS-0650081	Nylon Nut	3/4"-10	1
40	JWL1440VS-240E	Set Screw (Not Shown)	5/16"-18x2-1/2"	4
41	TS-0680032	Flat Washer (Not Shown)	5/16"	4
42	TS-0640081	Nut (Not Shown)	5/16"	4
43	JWL1440VS-243E	Warning Label (Not Shown)		1

JWL-1440VS Leg Set – Exploded View (OPTIONAL)

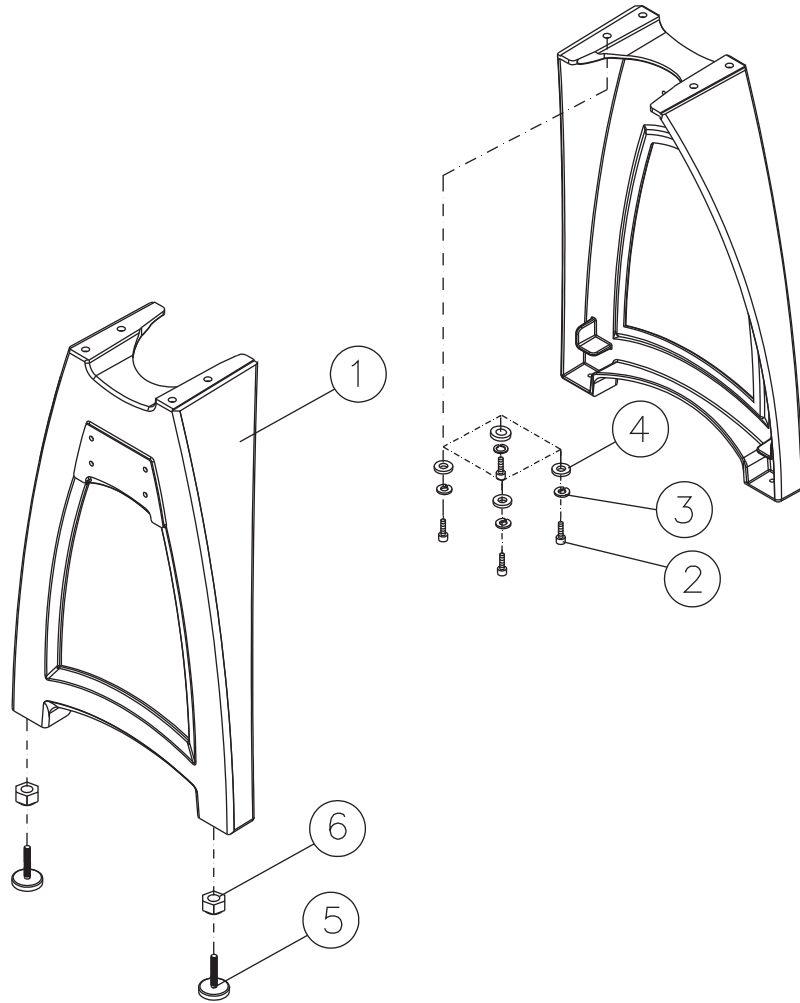

16.3.2 JWL-1440VS Leg Set – Parts List

Index No.	Part No.	Description	Size	Qty
.....	719402	JWL-1440VS Leg Set (includes #1 thru 6)	1
1	JWL1440-401	Leg	2
2	TS-0208071	Socket Head Cap Screw	5/16"-18x1-1/4"	8
3	TS-0720081	Lock Washer	5/16"	8
4	TS-0680031	Flat Washer	5/16"	8
5	JWL1642-206	Adjustable Foot	3/8"	4
6	TS-0561031	Hex Nut	3/8"-16	4
.....	JWL1440-HP1	Hardware Package (includes #2,3,4)

16.4.1 JWL-1440VS Extension Bed Assembly (OPTIONAL) – Exploded View

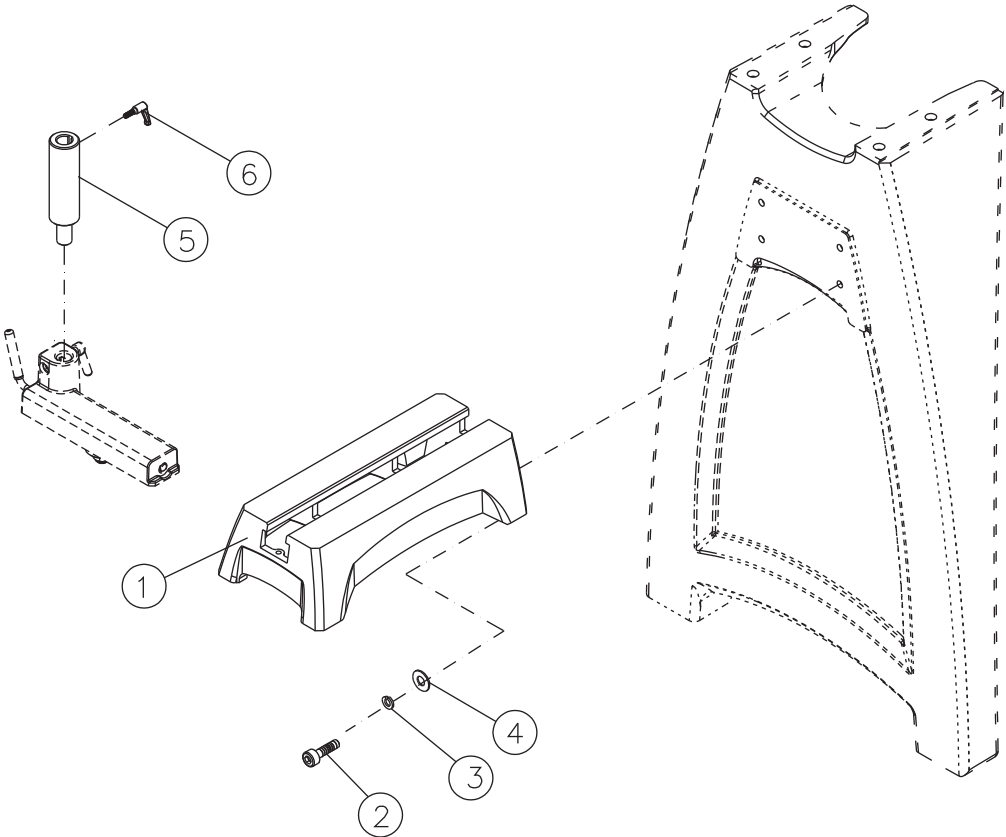

16.4.2 JWL-1440VS Extension Bed Assembly (OPTIONAL) – Parts List

Index No.	Part No.	Description	Size	Qty
.....	719401	20" Extension Bed w/ Post (includes #1 thru 6)	1
1	JWL1440-301	Extension Bed	20"	1
2	TS-0209071	Socket Head Cap Screw	3/8"-16x1-1/2"	4
3	TS-0720091	Lock washer	3/8"	4
4	TS-0680041	Flat Washer	3/8"	4
5	3520B-310	Extension Post	1
6	6294763	Locking Handle	1

JWL-1440VS-M...719400M...1 ~ 230V, 50Hz

	colour of strands	Litzenfarben	couleur des cordons
BK	black	schwarz	noir
WH	white	weiß	blanc
BU	blue	blau	bleu
YE	yellow	gelb	jaune
RD	red	rot	rouge
BN	brown	braun	brun
GY	grey	grau	gris
GNYE	green-yellow	grün-gelb	vert-jaune
OG	orange	orange	orange
VT	violet	violett	violet

	meaning of symbol	Bedeutung der Zeichen	interprétation
M	motor	Motor	moteur
S	switch	Schalter	interrupteur
C	condenser	Kondensator	condensateur
E	electronic unit	Elektronik Einheit	unité électronique
F	fuse	Sicherung	fusible
RS	reversing switch	Drehrichtungsschalter	commu. droite/gauche
S	centrifugal switch	Fliehkraftschalter	déclencheur centrifuge
OL	overload cut-off	Überlastschuttschalter	déclencheur surcharge
LS	limit switch	Positionsschalter	micro

